

# Smart String Inverter

SUN2000-17/20KTL



## Smart

- 6 strings intelligent monitoring and fast trouble-shooting
- RS485 and USB ports for communication and data management
- Local graphic LCD display and remote monitoring

## Efficient

- Max. efficiency 98.6%
- European efficiency 98.3%
- 3 MPPT per unit, effectively reducing string mismatch

## Safe

- DC switch integrated, safe and convenient for maintenance
- Residual Current Monitoring Unit (RCMU) integrated
- Fuse free design

## Reliable

- Natural cooling technology
- Protection degree of IP65
- Type II surge arresters for both DC and AC



# Smart String Inverter (SUN2000-17/20KTL)



Technical Specifications	SUN2000-17KTL	SUN2000-20KTL
<b>Efficiency</b>		
Max. Efficiency	98.6%	98.6%
European Efficiency	98.3%	98.3%
<b>Input</b>		
Max. Input Voltage	1,000 V	1,000 V
Max. Current per MPPT	18 A	18 A
Max. Short Circuit Current per MPPT	25 A	25 A
Start Voltage	250 V	250 V
MPPT Operating Voltage Range	200 V ~ 950 V	200 V ~ 950 V
Rated Input Voltage	620 V	620 V
Number of Inputs	6	6
Number of MPP Trackers	3	3
<b>Output</b>		
Rated AC Active Power	17,000 W	20,000 W
Max. AC Apparent Power	18,700 VA	22,000 VA
Max. AC Active Power (cosφ=1)	18,700 W	22,000 W
Rated Output Voltage	220 V / 380 V, 230 V / 400 V, 3W + N + PE	220 V / 380 V, 230 V / 400 V, 3W + N + PE
Rated AC Grid Frequency	50 Hz / 60 Hz	50 Hz / 60 Hz
Rated Output Current	25.8 A @380 V, 24.7 A @400 V	30.4 A @380 V, 29 A @400 V
Max. Output Current	28.5 A	33.5 A
Adjustable Power Factor Range	0.8 LG ... 0.8 LD	0.8 LG ... 0.8 LD
Max. Total Harmonic Distortion	<3%	<3%
<b>Protection</b>		
Input-side Disconnection Device	Yes	Yes
Anti-islanding Protection	Yes	Yes
AC Overcurrent Protection	Yes	Yes
DC Reverse-polarity Protection	Yes	Yes
PV-array String Fault Monitoring	Yes	Yes
DC Surge Arrester	Type II	Type II
AC Surge Arrester	Type II	Type II
DC Insulation Resistance Detection	Yes	Yes
Residual Current Monitoring Unit	Yes	Yes
<b>Communication</b>		
Display	Graphic LCD	Graphic LCD
RS485	Yes	Yes
USB	Yes	Yes
<b>General</b>		
Dimensions (W x H x D)	520 x 610 x 266 mm (20.5 x 24.0 x 10.5 inch)	520 x 610 x 266 mm (20.5 x 24.0 x 10.5 inch)
Weight (with mounting plate)	50 kg (110.2 lb.)	50 kg (110.2 lb.)
Operating Temperature Range	-25 °C ~ 60 °C (-13°F ~ 140°F)	-25 °C ~ 60 °C (-13°F ~ 140°F)
Cooling Method	Natural Convection	Natural Convection
Max. Operating Altitude	3,000 m (9,842 ft.)	3,000 m (9,842 ft.)
Relative Humidity	0 ~ 100%	0 ~ 100%
DC Connector	Amphenol Helios H4	Amphenol Helios H4
AC Connector	Amphenol C16/3	Amphenol C16/3
Protection Degree	IP65	IP65
Topology	Transformerless	Transformerless
<b>Standard Compliance (more available upon request)</b>		
Certificate	EN 62109-1/-2, IEC 62109-1/-2, IEC62116	
Grid Code	IEC 61727, NB/T 32004-2013, VDE-AR-N-4105, VDE 0126-1-1, G59/3, UTE C 15-712-1, CEI 0-16, CEI 0-21, C10/11 EN 50438-Ireland, EN 50438-Turkey, AS 4777, PEA (Only 20KTL), MEA (Only 20KTL), NRS 097-2-1	

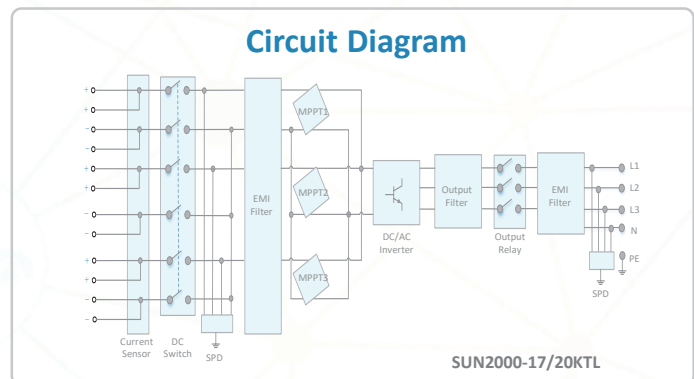
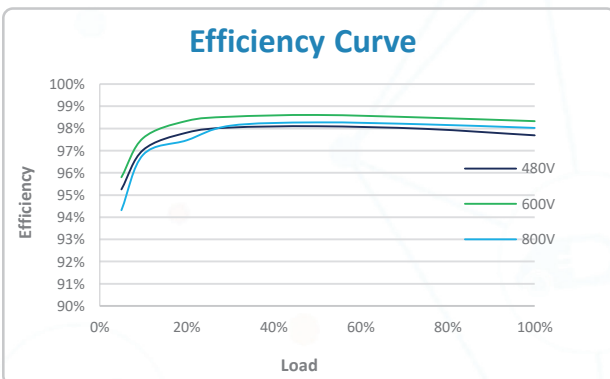

The text and figures reflect the current technical state at the time of printing. Subject to technical changes. Errors and omissions excepted. Huawei assumes no liability for mistakes or printing errors. For more information, please visit solar.huawei.com. Version No.:01-(201812)

